

## EOS Future

### Heater for Sauna Cabins



# Documentation

## Manufacturer

EOS Saunatechnik GmbH	
Schneiderstriesch 1	
35759 Driedorf, Germany	
Tel.	+49 2775 82-514
Fax	+49 2775 82-431
Email	servicecenter@eos-sauna.com
Web	www.eos-sauna.com







## Original installation instructions EN

Copyright for these installation instructions remains with EOS Saunatechnik GmbH.

The copying and distribution of this document, as well as the use and communication of its contents without express authorisation, are not permitted. Compensation will be claimed in the event of infringements.

All rights reserved with regard to patent claims or submission of design or utility patent.

## Characters, symbols and illustrations

-  Additional information about an operating step
-  Cross-reference to a page
-  Read instructions
-  Result of a step
-  Table title
-  Title of figure
- $\leq$   $\geq$  Less than or equal to, greater than or equal to

## Revision history

Date	Version	Description
23.01.2023	01.00	First version
28.02.2024	01.01	Design correction

## Contents

<b>Documentation</b> .....	EN-2
<b>1 General safety instructions</b> .....	EN-5
1.1 Mounting and electrical installation .....	EN-5
1.2 Operator instruction .....	EN-7
1.3 Safety levels.....	EN-9
1.4 Standards and regulations.....	EN-9
<b>2 Identification</b> .....	EN-10
2.1 Requirements for operation.....	EN-10
2.2 Nameplate .....	EN-10
2.3 Scope of delivery .....	EN-11
2.4 Accessories (optional).....	EN-11
2.5 Technical data .....	EN-12
2.6 Intended use .....	EN-13
<b>3 Installation</b> .....	EN-15
3.1 Specifications for the cabin .....	EN-15
3.1.1 Installation site .....	EN-16
3.1.2 Air inlets and outlets.....	EN-17
3.1.3 Temperature sensor.....	EN-19
3.2 Heater guard rail.....	EN-20
3.3 Preparing for installation.....	EN-20
3.4 Connecting cable .....	EN-22
3.5 Installing the heater .....	EN-26
<b>4 Electrical installation</b> .....	DE-28
4.1 General instructions for electrical installation .....	DE-28
4.2 Inner wiring diagrams .....	DE-28
4.2.1 Connecting to 400 V 3N ~ .....	DE-29
4.2.2 Connecting to 230 V 1N ~ .....	DE-32
4.2.3 Internal wiring.....	DE-33
4.3 Establishing an electrical connection .....	DE-35
4.4 Heating period limitation.....	DE-35
<b>5 Commissioning</b> .....	EN-36
5.1 Filling with stones .....	EN-36
5.2 Starting the heater.....	EN-37
5.3 Switching the heater on remotely .....	EN-37
5.4 Water splash.....	EN-38

<b>6</b>	<b>Service and maintenance</b> .....	EN-39
6.1	Cleaning .....	EN-39
6.2	Sauna stones .....	EN-40
6.3	Replacing the tubular heating elements .....	EN-41
6.4	Troubleshooting .....	EN-46
<b>7</b>	<b>General terms and conditions of service</b> .....	EN-47
<b>8</b>	<b>Disposal</b> .....	EN-50

# 1

## General safety instructions

### 1.1 Mounting and electrical installation



The installation instructions are intended for qualified personnel familiar with the laws and regulations applicable to electrical installations at the installation site. Observe the following general safety instructions during mounting, configuration and commissioning of the product.

#### **Risk to life and limb and risk of fire**

Risk to life and limb from electric shock and fire in the event of improper or faulty electrical connection. This risk remains also after completion of the installation work.

- ▶ The electrical installation of the heater, power extension units and other electrical systems or equipment with a fixed mains connection must only be performed by a trained electrician from an authorised electrical company.
- ▶ Ensure compliance with the applicable standards and regulations for electrical installation.
- ▶ The system must be completely disconnected from the mains supply before commencing installation and repair work.
- ▶ The housing cover must only be removed by a qualified electrician.

#### **Fire hazard from overheating**

Insufficient ventilation can lead to device overheating and fire.

- ▶ Install air inlets and outlets in the cabin.
- ▶ Observe the cabin manufacturer's safety and installation instructions.

#### **Risk of fire due to sauna stones**

It is possible for hot stones or stone pieces to fall out of the rock store.

- ▶ The sauna heater may not be placed on a floor made of easily flammable material (e.g. laminate or synthetic flooring). Ceramic tiles are recommended as a flooring option.

## General safety instructions

- Risk of burns from hot glass** Glass surfaces in the cabin become hot while the sauna is in operation.
- ▶ When installing the cabin, ensure that the touchable glass surfaces on the outside of the cabin may reach a maximum temperature of 76°C. Appropriate protection may need to be installed if required.
- Risk of burns from hot unit** During operation, the sauna heater may become hot and, if touched, could cause burns.
- ▶ Maintain a safe distance.
- Sauna cabin and sauna heater** The sauna cabin must be constructed with proper material and built in a professional manner, and the sauna heater must be suited for the cabin.
- ▶ The sauna heater may only be used in sauna cabins made of suitable, low-resin and untreated material (e.g. Nordic spruce). The control unit must not be used in the cabin.
  - ▶ Multiple heaters may be installed in one sauna if the heater output can properly supply the cabin volume. In this case, depending on the position, an additional safety temperature limiter must be installed for each additional heater.
  - ▶ The sauna heater is not designed to be installed or set up in an alcove or under a bench or sloping roof unless the sauna heater is specifically designed and approved for this type of installation.
  - ▶ Receptacles may not be installed inside the sauna cabin.
  - ▶ Each sauna cabin must have air inlets and outlets. The air inlets and outlets may be installed from below or from behind the heater. The minimum dimensions of the air inlets and outlets can be found here: 2.5 Technical data, □ EN-12, 3.1.2 Air inlets and outlets, □ EN-17.
  - ▶ The air outlet is always installed in the lower part of the wall, diagonal to the sauna heater. The air inlets and outlets must not be closed. Please observe the instructions provided by your sauna cabin manufacturer.
  - ▶ Use one of the control units listed below to check and control the sauna heater. This control unit is fixed to a suitable location on the cabin's external wall, and the corresponding temperature sensor according to the installation instructions that accompany the control units inside the sauna cabin.

- ▶ Electrical installations and equipment in the sauna cabin must comply with IEC 60364-7-703 (DIN VDE 0100-703).
- ▶ The cabin lighting must be safe for sauna cabin use and installed in such a way that it can be used safely in a sauna cabin. Ensure that the heater is installed in compliance with the standards and legal norms valid in your country.
- ▶ The cabin door must open outward and must not have a lock that cannot be opened in the case of failure. We recommend magnetic or spring locks.
- ▶ The door opening should be > 80 cm.

## 1.2 Operator instruction

The operator of the sauna cabin must be instructed in the general safety instructions during commissioning. The operator must be given a copy of the operating instructions.

### Risk of electric shock

A risk to life and limb from electric shock and fire arises in the event of improper repair work. This risk remains also after work is completed.

- ▶ The housing cover must only be removed by a trained specialist.
- ▶ Repairs and installations must only be performed by a trained specialist.
- ▶ The system must be disconnected and removed entirely from the mains supply before commencing repair work.
- ▶ Use only original spare parts from the manufacturer.

### Fire hazard



Objects placed on the heater can easily be ignited and cause fires.

- ▶ Do not place objects on the heater.
- ▶ Fill the rock store as directed.
- ▶ Attach the heater guard rail.
- ▶ Inspect the sauna cabin prior to each commissioning.
- ▶ If you operate the sauna heater using pre-set timers or a remote control, install a suitable safety system.

### Health risks

Spending time in a sauna cabin can lead to serious health risks or even death for persons with health impairments.

- ▶ Persons with health impairments who spend time in a sauna must consult a doctor before entering a sauna cabin.

## General safety instructions

### **Equipment damage due to overuse**

If the cabin is used commercially, the heating time must be set so that the heater switches off automatically after a specific period of time.

- ▶ If the heating does not switch off automatically after a defined heating period, cabin use must be supervised at all times.
- ▶ Inspect the cabin before each use.

### **Damage to health**

Excessive time spent in a heated sauna cabin can lead to overheating of the body (hyperthermia), which may cause serious health problems and even death. Hyperthermia occurs when the core temperature of the body exceeds the norm by a few degrees. Symptoms of hyperthermia include fever, dizziness, lethargy, sleepiness, and fainting. Side effects of hyperthermia include perception disorders, inability to recognize the need to leave the room, inability to identify imminent danger, harm to the foetus in the case of pregnant women, inability to physically leave the room, unconsciousness.

Alcohol, drugs, and medications increase the risk of hyperthermia.

- ▶ Do not exceed the maximum recommended time in the sauna.
- ▶ Leave the sauna cabin if your body responds abnormally to the heat or if you do not feel well.
- ▶ Avoid alcohol, drugs, and medications when you are using the sauna.

### **Operation by children or persons with reduced mental capacity**

This unit should not be used by children or persons with reduced mental capacity or limited physical or sensory abilities.

- ▶ Children must be supervised to ensure they do not play with the unit.
- ▶ Children and persons who have not received proper instruction must not clean or service the system.



## 1.3 Safety levels

Safety instructions and important operating instructions are classified according to ANSI Z535.6. Please familiarise yourself with the following terms and symbols:

### **WARNING**

#### **Warning**

Indicates a hazardous situation which, if not avoided, could result in death or serious injury.

---

### **CAUTION**

#### **Caution**

Indicates a hazardous situation which, if not avoided, could result in minor or moderate injury.

---

### **NOTICE**

#### **Notice**

Indicates a hazardous situation which, if not avoided, will result in damage to the unit.

---

## 1.4 Standards and regulations

For an overview of the standards that were observed during design and construction of the sauna heaters, please refer to the individual product's technical data sheet that can be downloaded from [www.eos-sauna.com](http://www.eos-sauna.com). Local regulations also apply to the installation and operation of heating, sauna, and steam room systems.

# Identification

## 2

### Identification

EOS Future/Future Stone is an electrically heated sauna heater for Finnish mode available in a variety of output capacities.

#### 2.1 Requirements for operation

The heater must be operated with one of the following control units:

- EmoStyle series
- EmoTec series
- EmoTouch series
- Econ series (Econ D2 and higher)
- Compact series

The control unit is not included in the scope of delivery.

A power extension unit is also required for the output capacities 12 and 15 kW.

#### 2.2 Nameplate

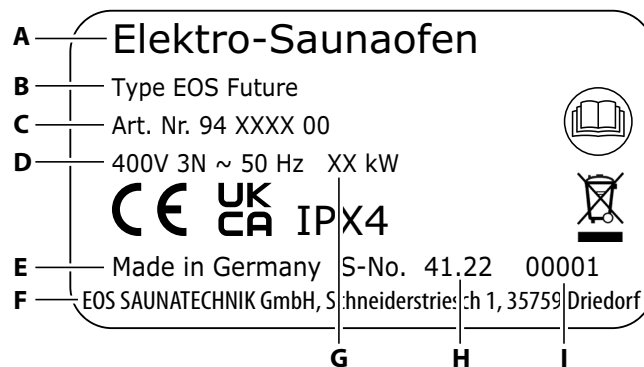

- |                                |                             |
|--------------------------------|-----------------------------|
| <b>A</b> Name                  | <b>F</b> Manufacturer       |
| <b>B</b> Model                 | <b>G</b> Heater output      |
| <b>C</b> Item number           | <b>H</b> Manufacturing date |
| <b>D</b> Electrical connection | <b>I</b> Serial number      |
| <b>E</b> Country of origin     |                             |

## 2.3 Scope of delivery

Check the unit upon delivery to ensure that all components were delivered and that it is in proper working order. Contact your distributor if components are missing or damaged. The unit must not be operated if components are missing or damaged.

The base plate is made of different stone variations depending on the model.

The following parts are included in the scope of delivery:

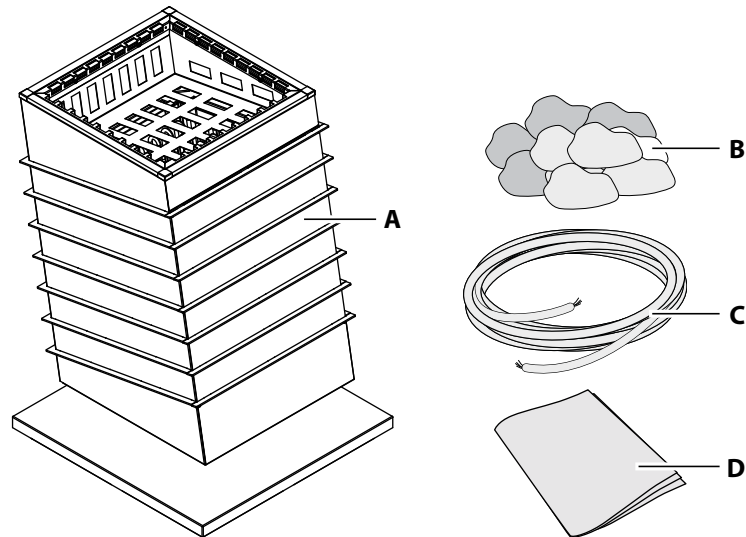

- A** Future sauna heater with base plate
- B** Sauna stones, 40 kg  
Caliber 50–100 mm
- C** Connecting cable, 8 m, pre-installed
- D** Installation and Operating Instructions

## 2.4 Accessories (optional)

Accessories (optional)	Item number
Heater guard rail bracket for Future	94.8108
Heater guard rail, stainless steel + heater guard rail bracket for Future (completely pre-assembled)	94.8109

It is essential that the unit is protected from being touched. We recommend using an EOS heater guard rail.

# Identification

## 2.5 Technical data

Heater output	9 kW	10 kW	12 kW	15 kW
Unit dimensions HxWxD in cm	90 x 60 x 60			
For cabin volume	9–14 m <sup>3</sup>	11–15 m <sup>3</sup>	14–18 m <sup>3</sup>	18–25 m <sup>3</sup>
Minimum size Air inlets and outlets	35 x 6 cm		35 x 7 cm	35 x 9 cm
Weight without rocks	Future: 87.5 kg Future Stone: 88.5 kg			
Stone filling weight	~ 40 kg			
Caliber	50–100 mm			
Power extension unit	No		LSG 10*	
Power connection	400 V 3N ~ 50 Hz			
Connection mains – control unit	5 x 2.5 mm <sup>2</sup>			
Connection control unit – heater	5 x 1.5 mm <sup>2</sup>			
Connection mains – LSG	-		5 x 2.5 mm <sup>2</sup>	
Connection LSG – heater	-		5 x 1.5 mm <sup>2</sup>	
Connection control unit – LSG	-		4 x 1.5 mm <sup>2</sup>	
Leakage current	Max. 0.75 mA per kW heater output			
Fuse protection for control unit	3 x 16 A			
Fuse protection for LSG unit	3 x 16 A			

All line cross-section specifications are the minimum cross-sections for the copper line. The sauna heater must be operated by a sauna control unit.

\*) Not required for Compact D18/H18 control units

## 2.6 Intended use

This heater is intended solely for the purpose of heating sauna cabins, together with a suitable control unit.

EOS Future/Future Stone is suitable for commercial and private use.



The heater is not suitable for outdoor use.

It must be operated only inside buildings and may not be exposed to environmental conditions such as extreme humidity and moisture or the possible formation of condensation or corrosive substances in the ambient air, as well as other weather conditions.

Any use beyond this is considered improper use. Proper use also includes compliance with operating, maintenance and servicing requirements.

### Foreseeable misuse

The following are considered instances of foreseeable misuse:

- The heater power does not match the sauna volume.
- The control and sensor cable plugs are plugged in incorrectly.
- The unit is operated without knowledge of or compliance with the safety instructions.
- Operating, service and maintenance requirements are not observed.
- The unit is operated after technical or other modifications are made to the relay box.
- The unit is operated with insufficient air supply or exhaust air.
- The unit is operated without sauna stones or with a rock store that is not filled as directed.
- The unit is operated by children under 8 years of age.
- The unit is operated by children 8 years of age or older, or persons with reduced mental capacity who have not been thoroughly instructed in its use.

The manufacturer is not liable for unauthorised modifications made to the equipment and damages resulting from these modifications. The person modifying the equipment alone shall bear the associated risk.

# Identification

## General instructions

- Please note that an optimal sauna climate can be achieved only if the cabin with its air inlets and outlets, the sauna heater, and the control unit are synchronized.
- Observe the specifications and information provided by your sauna retailer.
- The sauna heaters heat the sauna cabin with heated convection air. Fresh air is drawn in through the air inlet. It is warmed and rises (convection) and is then circulated in the cabin. Some of the used air is pushed out of the cabin through the cabin's air outlet. This creates a typical sauna climate in which temperatures of approx. 110°C are achieved directly below the ceiling. These temperatures drop to approx. 30–40°C in the cabin along the floor. Therefore, it is not unusual that if the temperature sensor above the sauna heater reads 110°C, the thermometer that is mounted approx. 20–25 cm below the cabin ceiling on the cabin wall reads only 85°C.  
When the max. temperature is set for the area around the upper sauna bench, the bathing temperature is typically between 80°C and 90°C.
- Please note that the highest temperatures in the cabin are always above the sauna heater and that is where the temperature sensor and safety temperature limiter should be mounted according to the installation instructions.
- The first time the cabin is heated, you may notice a slight odour resulting from the evaporation of consumables used in the manufacturing processes. Air out your cabin once it has been heated and before using the sauna.

# 3

## Installation

This chapter describes how to install Future. Prior to installing the unit, air inlets and outlets must be installed in the cabin. It may be necessary to mount additional fans in the inlets/outlets. All protective films must be removed.

### NOTICE

#### Damage due to incorrect mounting location

The heater is not suitable for outdoor use.

- ▶ The heater must be operated only inside buildings and may not be exposed to environmental conditions such as extreme humidity and moisture or the possible formation of condensation or corrosive substances in the ambient air, as well as other weather conditions.
- ▶ The heater is not designed to be installed or set up in an alcove or under a bench or sloping roof.

### 3.1 Specifications for the cabin

The cabin must be planned and installed according to specifications before the heater is installed. It must be ensured that the heater can be removed from the cabin even after the cabin has been installed

All electrical installations laid inside the cabin must be suitable for silicone cables and a temperature of at least 170°C.

All lines must be routed in such a way that they are well-protected, e.g. in a cable duct. EOS recommends laying all connecting cables through a bendable metal tube connected to the protective conductor.

The floor on which the heater stands must be level.

In general, it should be noted that the sauna heater must not be set on a floor made of highly flammable material (laminated, flooring made of plastic material, etc.). Ceramic tiles are recommended as a flooring option.

# Installation

## 3.1.1 Installation site

The sauna heaters output selected must be appropriate for the cabin volume; see 2.5 Technical data, [EN-12](#).

- Ceiling height of at least 190 cm
- Distance heater – cabin wall min. 8 cm (base plate serves as orientation)
- Distance heater – bench (lower than heater) min. 5 cm
- Distance heater – bench (higher than heater) min. 8 cm
- Distance heater – flammable material (wood wall, sauna bench, etc.); see the following figures.
- A heater guard rail must be mounted around the upper edge of the heater. It prevents accidental contact with hot parts of the heater.

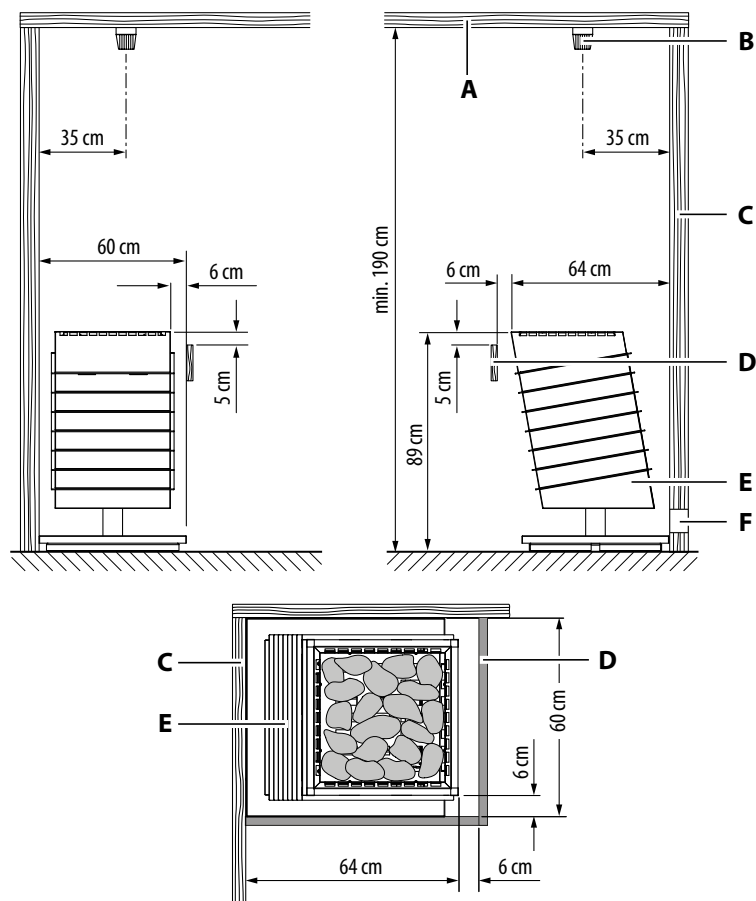

- |                             |                            |
|-----------------------------|----------------------------|
| <b>A</b> Cabin ceiling      | <b>D</b> Heater guard rail |
| <b>B</b> Temperature sensor | <b>E</b> Heater            |
| <b>C</b> Cabin wall         | <b>F</b> Air inlet         |

 Dimensions in the cabin



## 3.1.2 Air inlets and outlets

Air inlets and outlets must be installed in the cabin to ensure a sufficient air flow in the cabin and to prevent the heater from overheating. The required size of the air inlets and outlets depends on the heater output; see 2.5 Technical data, [EN-12](#).

### **⚠ WARNING**

#### **Fire hazard from overheating**

The heater can overheat if the air supply is insufficient. There is a risk of death due to fire.

- ▶ Ensure that the air inlets and outlets provide sufficient ventilation. Install a fan if necessary.
  - ▶ Start the sauna only after all air inlets and outlets have been opened.
- 

### **NOTICE**

#### **Heating process takes too long**

If the heating process takes a long time, the underlying reason is that the sauna heater receives insufficient air.

- ▶ A minimum of 5 times the cabin volume of air per hour must be exchanged.
-

# Installation

## Air inlet

Depending on the location of the heater, the air inlet must be installed below or behind the heater.

- Heater is located in the middle of the cabin: air inlet from below
- Heater is located in front of the cabin wall: air inlet from the side
- If the natural air flow is insufficient, a fan may need to be installed at the air inlet side.

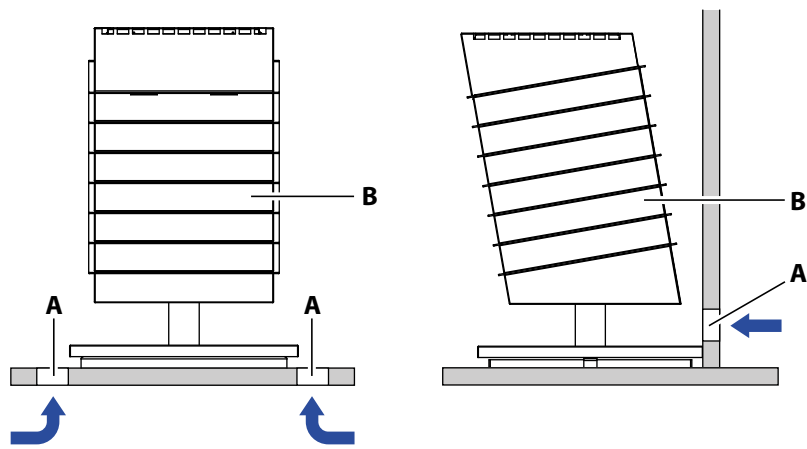

**A** Air inlet

**B** Heater

☒ Supply air from below (figure on the left) and from the side (figure on the right)

## Air outlet

The air outlet must meet the following criteria:

- Position: across from the heater
- Height: 30–50 cm above the cabin floor

### 3.1.3 Temperature sensor

It is essential that the temperature sensor with the safety temperature limiter (STB) is installed.

The temperature sensor with the safety temperature limiter is not included in the scope of delivery.



#### **⚠ WARNING**

##### **Risk of fire due to incorrect temperature sensor position**



Overheating can occur if the temperature sensor is installed in the incorrect position; in this case, the sensor may read a lower temperature than actually exists in the cabin.

This would trigger the sauna heater to continue to heat, even though the desired temperature has

already been reached.

- ▶ Install the sensor as shown in the figure  Dimensions in the cabin,  EN-16.

The temperature sensor must be installed where expected temperatures are the highest, meaning above the heater.

For placement, see  Dimensions in the cabin,  EN-16.

#### **NOTICE**

##### **Malfunction due to damaged temperature sensor**

The temperature sensor is protected by its housing.

- ▶ Ensure that the housing and the temperature sensor are not damaged during operation.

# Installation

## 3.2 Heater guard rail

### **⚠ CAUTION**

#### **Risk of burns if heater is touched.**

The outer casing of the heater may become hot and, if touched, could cause burns.

- ▶ It is essential that a heater guard rail is installed so that the unit is protected from being touched.
- 

A heater guard rail must be mounted around the upper edge of the heater. It prevents accidental contact with hot parts of the heater.

You can purchase a suitable heater guard rail from the sauna heater manufacturer. See 2.4 Accessories (optional), [EN-11](#)

## 3.3 Preparing for installation

The heater is supplied packaged on a pallet. The heater and the base plate sit separately on the pallet. Once the cabin is prepared, the heater and the base plate are placed in a pre-defined position. Two people should always transport the heater and the base plate.

### ▶ **Unpacking the heater and base plate**

- 1 Remove the heater and base plate packaging.
  - ⓘ Leave the heater and base plate on the pallet.
- 2 Remove all transport locks and protective films in the heater.

## ► Setting up the base plate

- 1 Move the pallet with the heater and base plate as close to the pre-defined installation site as possible.
- 2 Lift the base plate from the pallet and move it to the pre-defined installation site.
  - ① If the heater is placed in front of the cabin wall, the opening in the base of the base plate must face the cabin wall.

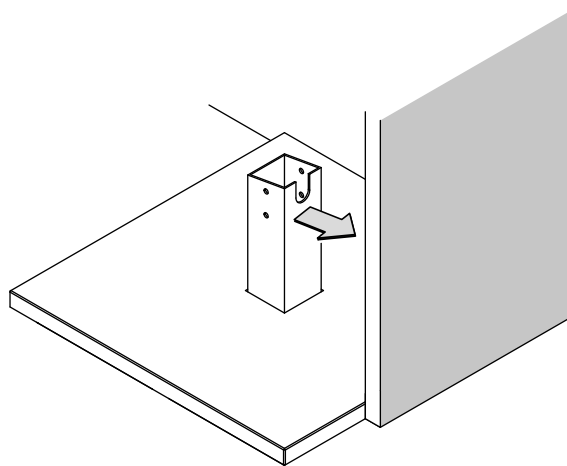

## ► Preparing the heater

- 1 Place an underlay on the floor in front of the base plate to protect the floor and the heater from damage.
- 2 Lift the heater from the pallet and place it on the underlay in front of the base plate.
  - ① The rear side of the heater must face upward.

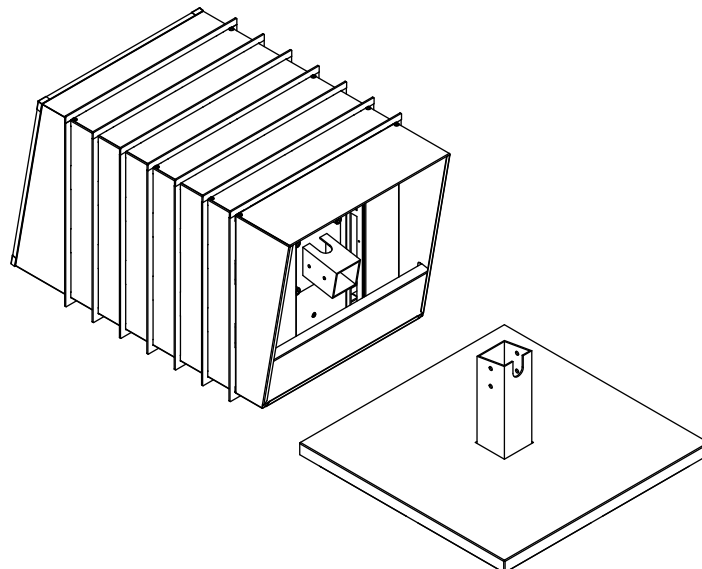

# Installation

## 3.4 Connecting cable

The connecting cable is pre-mounted on the sauna heater and must be routed through the base of the base plate.

The sauna heater must be connected to the control unit or control unit and relay box by means of one or two connecting cables, depending on the heater output.

Install the cables in such a way that they are protected from damage. To do this, route empty pipes from the installation site of the sauna heater to the relay boxes.

Outside of the cabin, the cables must be routed under a suitable protective cover (e.g. in a cable duct or empty conduits).

See the connection diagram: 4.2 Inner wiring diagrams,  DE-28.

If there are no empty pipes in your cabin, drill a hole in the cabin wall directly next to the sauna heater where the cable emerges from the sauna heater, and guide the cable through this hole outward to the control unit and relay box. The hole must be large enough to accommodate the cable. The cable and all other connecting cables (supply line to mains and cabin lighting) on the external side of the cabin must be protected from damage.

To do this, use installation pipes or attach a suitable protective cover.

If the electrical connection must be changed (e.g. when connecting to 230 V 1N ~), the following step is required:

► Changing the connecting cable (optional),  EN-24

### ► Laying the connecting cable

- 1 Route the connecting cable through the base of the base plate.

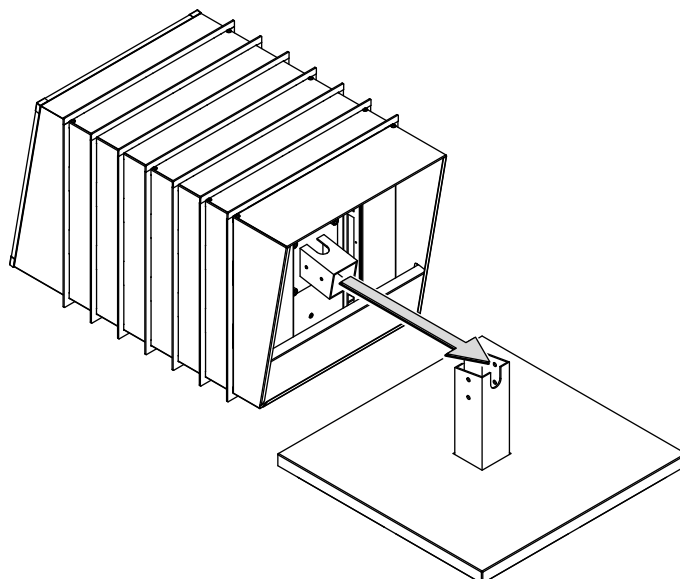

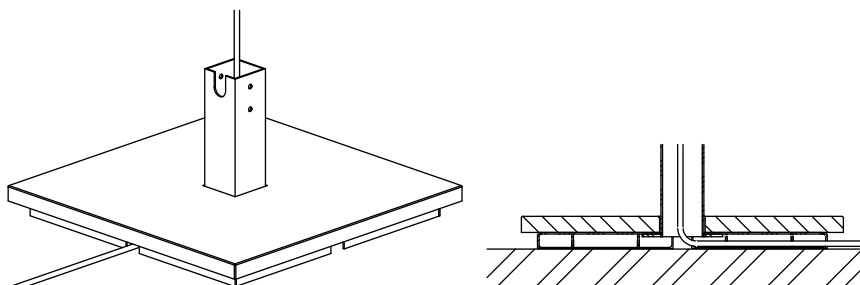

- 2 Lay the connecting cable along the heater base from the cabin to the control unit or power extension unit.

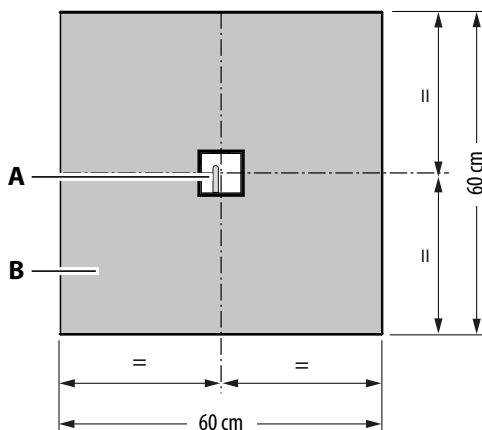

► **Laying the concealed connecting cable (optional)**

- 1 Attach the feed opening in the cabin floor under the base plate. Use a cable duct for this purpose.



- A** Hole for connecting cable      **B** Base plate  
 Drilling template for concealed connecting cable

- 2 Route the connecting cable through the base of the base plate.
- 3 Route the connecting cable under the cabin floor with a suitable protective cover.

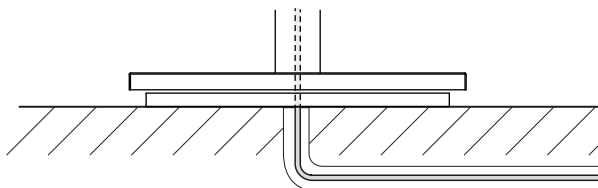

# Installation

## ► Changing the connecting cable (optional)

- 1 Loosen the screws in the back panel and remove it.

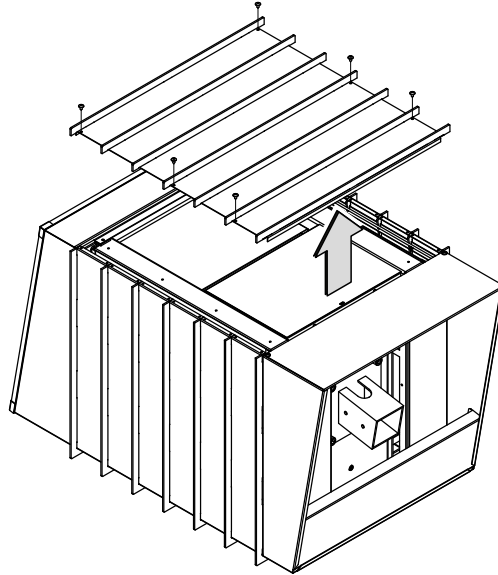

- 2 Loosen the screw on the cover of the terminal box and remove the cover.

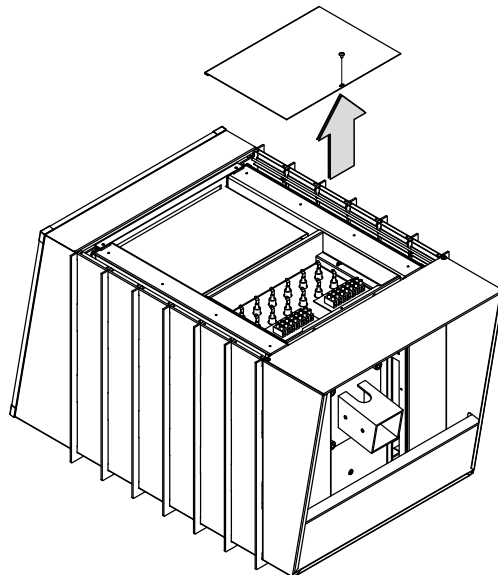

- 3 Disconnect the connecting cable in the terminal box.
- 4 Feed the connecting cables through the cable screw connection out from the heater.
- 5 Feed the new connecting cable through the cable screw connection on the terminal box and tighten the cable screw connection.



- 6 Connect the connecting cables as shown in the connection diagram. See the connection diagram 4.2.1 Connecting to 400 V 3N ~, □ DE-29 or 4.2.2 Connecting to 230 V 1N ~, □ DE-32  
① Terminal torque: 2.5–3 Nm
- 7 Feed the connecting cable through the opening in the heater base.

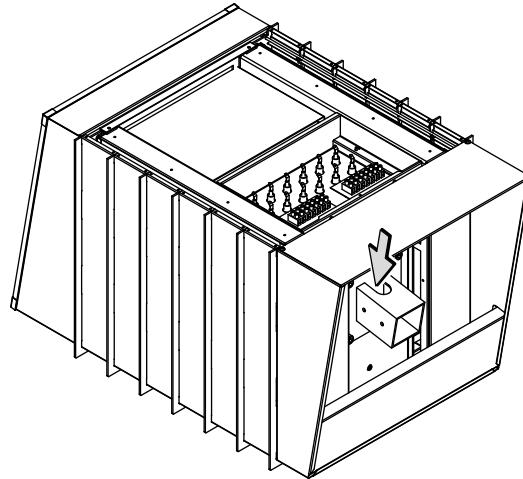

- 8 Fix the covers of the terminal box in place and screw in and tighten the screw.
- 9 Put the back panel in place and screw in and tighten the screws.

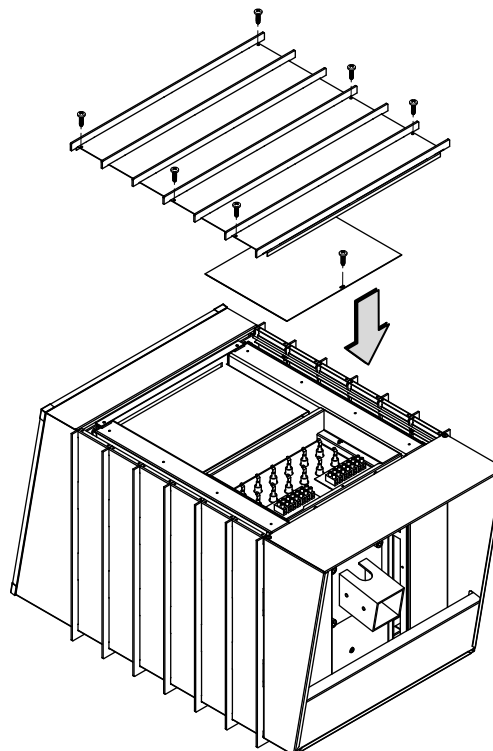

# Installation

## 3.5 Installing the heater

Two people should always transport the heater.

### ► Mounting the heater

- 1 Place the heater on the base of the base plate.  
① The openings for the cable feed opening in the heater base and in the base of the base plate must point in the same direction.
- 2 Tighten the connecting cable if necessary.
- 3 Loosen the screws in the lower back panel and remove it.

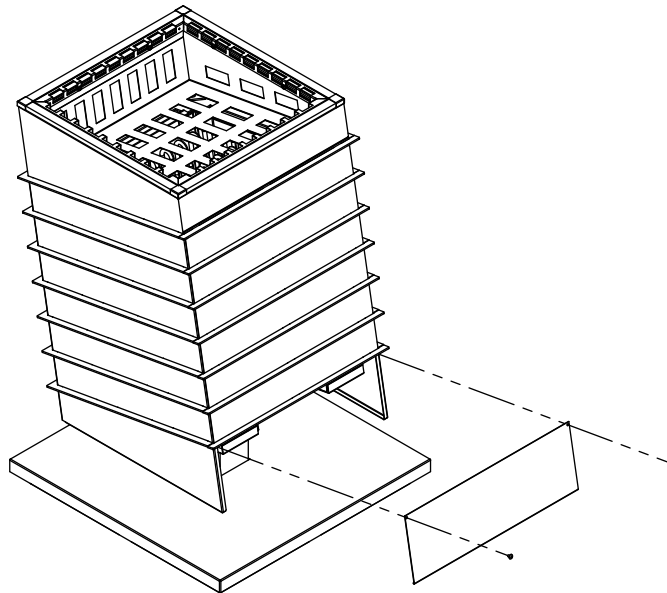

- 4 Unscrew 2 screws on the lower housing approx. 1 mm and remove the lower housing from the heater. Do not unscrew the screws completely.  
① The lower housing must only be removed if the heater is placed close to a wall. The heater base must be accessible.

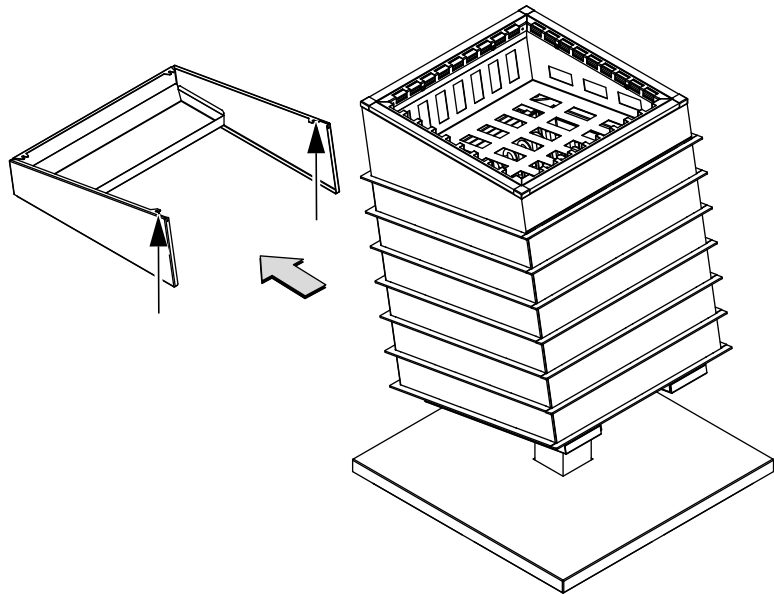

- 5 Screw the screws into the holes in the heater base and tighten them with a ring or socket spanner.

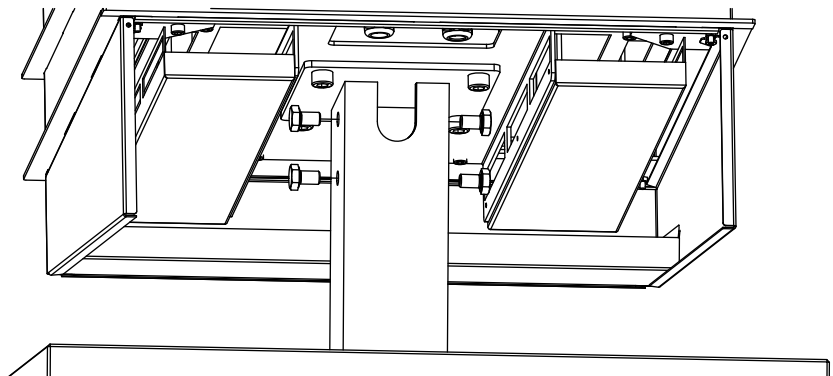

- 6 Put the lower housing and lower back panel in place.

# Electrical installation

# 4

## Electrical installation

### 4.1 General instructions for electrical installation

Ensure that electrical installation is performed in compliance with the standards and legal norms valid in your country.

Observe the following regulations when installing sauna heaters: IEC 60364-7-703 and/or DIN VDE 0100 part 703:

This most recent version of the standard under amendment of paragraph 703.412.05, states the following:

“The additional protection must be provided for all of the sauna's electric circuits by one or more residual current devices (RCDs) with a rated differential current no greater than 30 mA, with the exception of sauna heaters.”

If a residual current device (RCD) is installed, ensure that there are no other electrical consumers not belonging to the sauna system which are fused via this RCD.

If the sauna heater has not been used for an extended period of time, the heater may draw moisture from the ambient air, which, in rare cases, could lead to the RCD to be tripped. This is a physical process and not a fault on the part of the manufacturer.

In this case, the heater must be heated by a technician under supervision which will bypass the RCD function. Once the moisture has escaped from the heating elements after approx. 10 minutes, the RCD can be integrated again in the electric circuit.

If the sauna heater will not be used for an extended period of time, we recommend that you switch on the heater every 6 weeks so that the heating elements do not accumulate moisture. If, during commissioning, the RCD is triggered, the electrical installation must be checked again.

The electrician is responsible for properly connecting the heater; thus, the manufacturer does not assume liability.

### 4.2 Inner wiring diagrams

The sauna control unit and the heater must be connected as shown in the circuit diagrams.

Please observe the installation and operating instructions for the sauna control unit. See also 2.5 Technical data, [EN-12](#).

## 4.2.1 Connecting to 400 V 3N ~

### 9, 10, 12\* and 15\* kW heater output

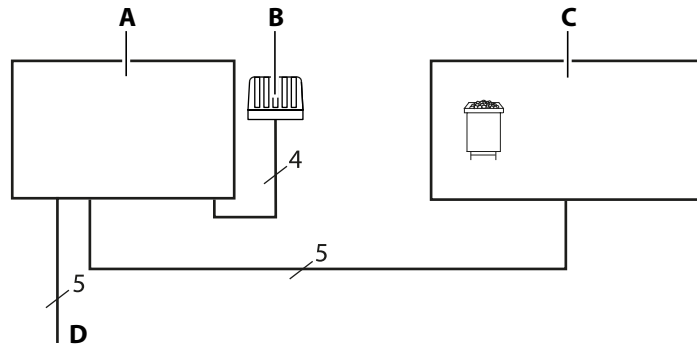

- A** Sauna control unit
- B** Temperature sensor and safety temperature limiter
- C** Heater
- D** Mains connection for sauna control unit

☒ Terminal diagram 9, 10, 12\* and 15\* kW

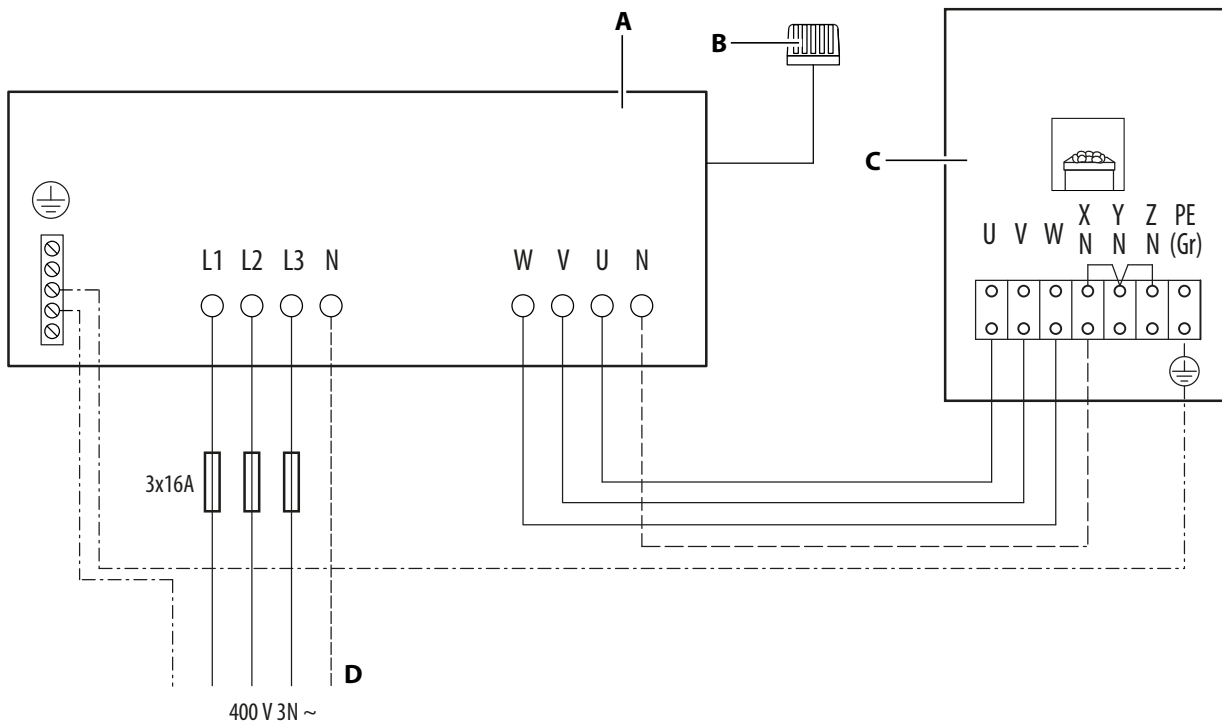

- A** Sauna control unit
- B** Temperature sensor and safety temperature limiter
- C** Heater
- D** Mains connection for sauna control unit

☒ Connection diagram 9, 10, 12\* and 15\* kW

Connection with the Econ control unit is possible only at 9 kW.

\*) Only for connecting to Compact D18/H18 control units.

# Electrical installation

## 12\* and 15\* kW heater output, single circuit (with power extension unit)

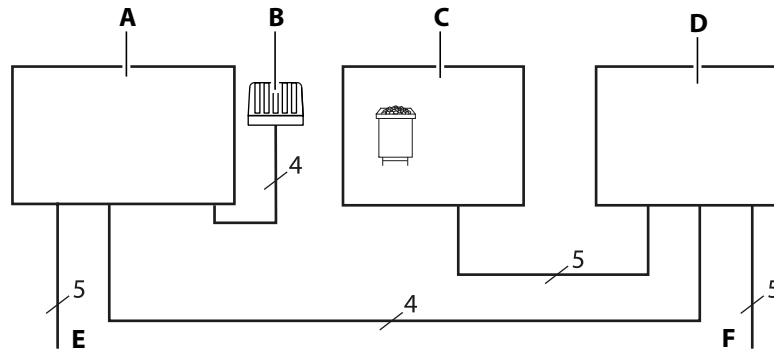

- A** Sauna control unit  
**B** Temperature sensor and safety temperature limiter  
**C** Heater  
**D** Power extension unit (LSG)  
**E** Mains connection for sauna control unit  
**F** Mains connection for power extension unit

☒ Terminal diagram 12\* and 15\* kW

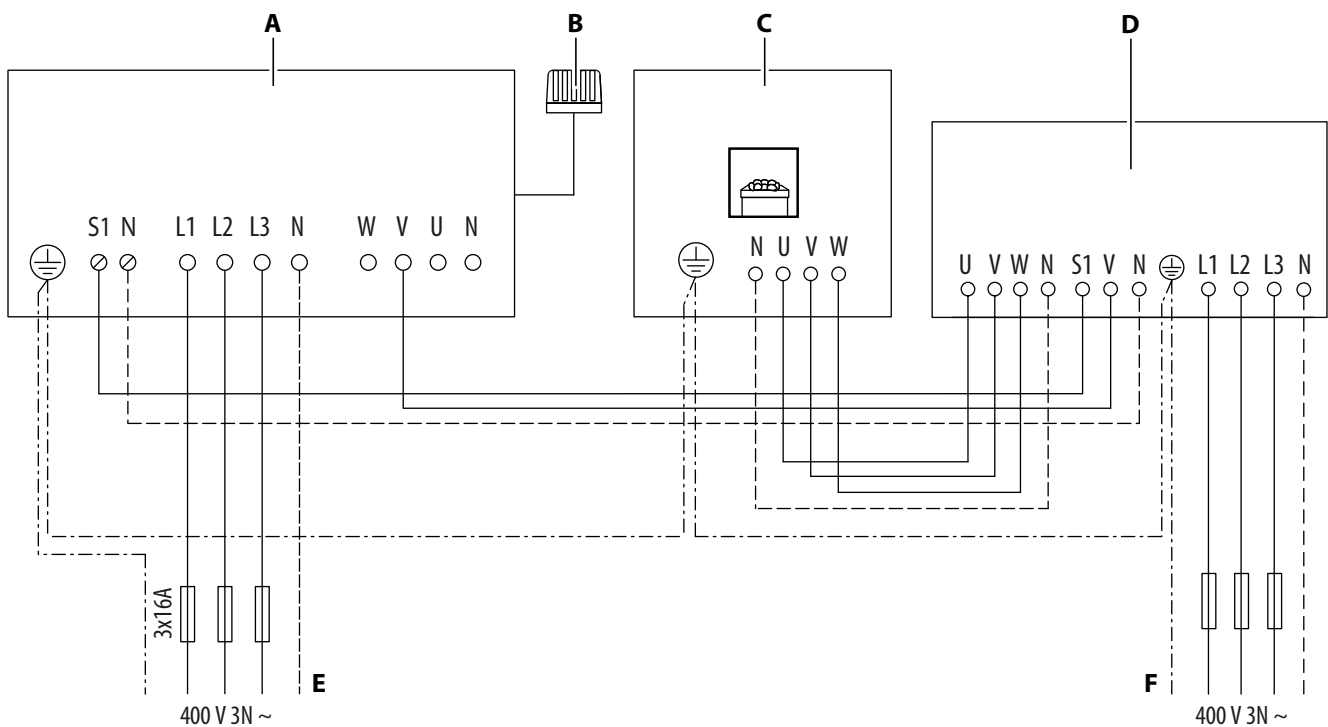

- A** Sauna control unit  
**B** Temperature sensor and safety temperature limiter  
**C** Heater  
**D** Power extension unit (LSG)  
**E** Mains connection for sauna control unit  
**F** Mains connection for power extension unit

☒ Connection diagram 12\* and 15\* kW

\*) Not for connecting to Compact D18/H18 control units.

## 12\* and 15\* kW heater output, double circuit (with LSG10)

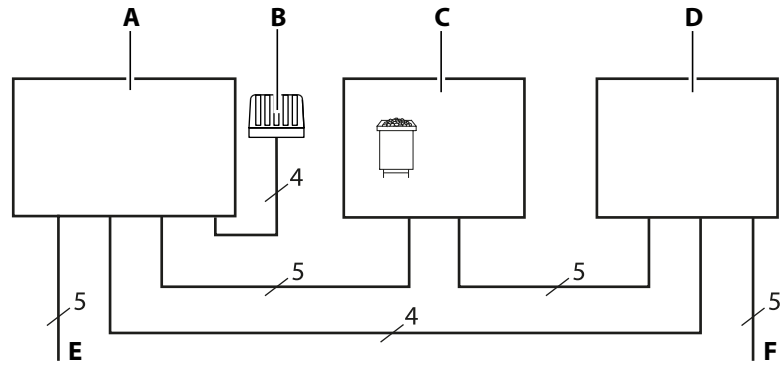

- A** Sauna control unit
- B** Temperature sensor and safety temperature limiter
- C** Heater
- D** LSG10
- E** Mains connection for sauna control unit
- F** Mains connection LSG10

☒ Terminal diagram 12\* and 15\* kW, double circuit

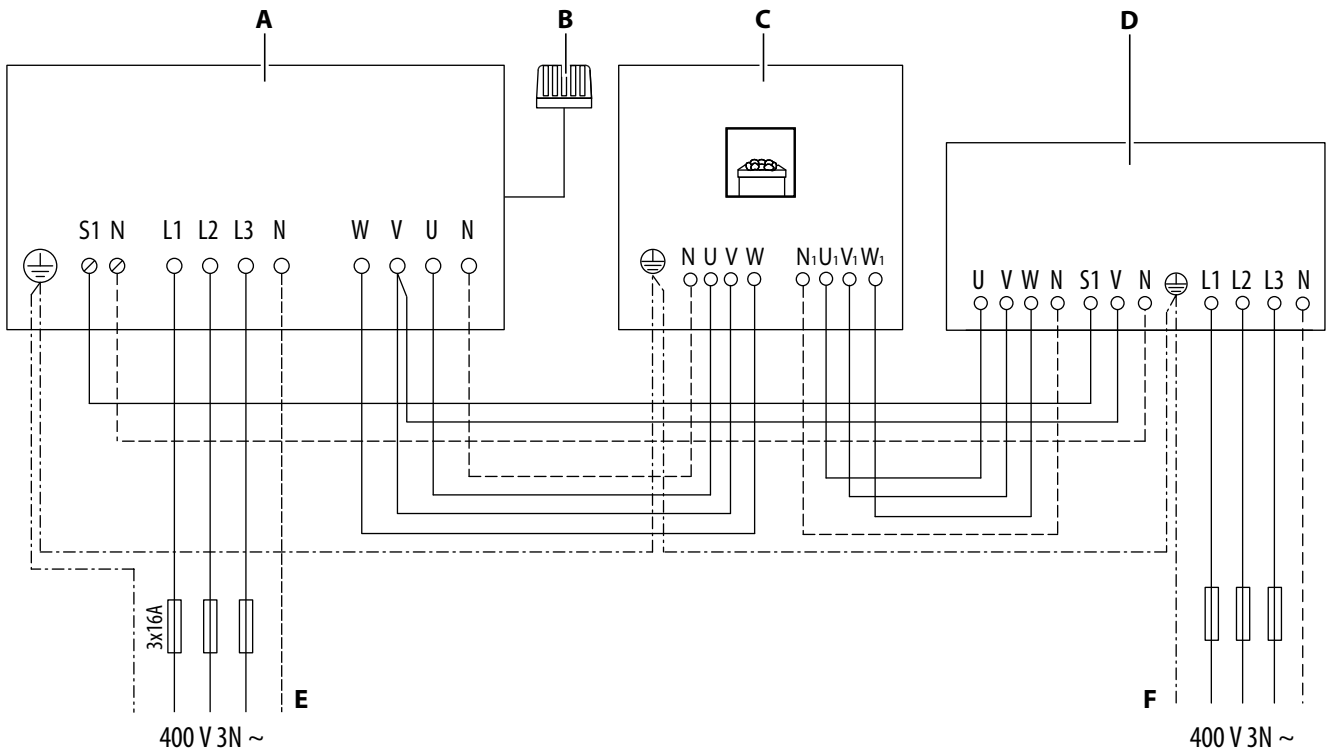

- A** Sauna control unit
- B** Temperature sensor and safety temperature limiter
- C** Heater
- D** Power extension unit (LSG)
- E** Mains connection for sauna control unit
- F** Mains connection LSG10

☒ Connection diagram 12\* and 15\* kW, double circuit

\*) Not for connecting to Compact D18/H18 control units.

# Electrical installation

## 4.2.2 Connecting to 230 V 1N ~

9 kW heater output

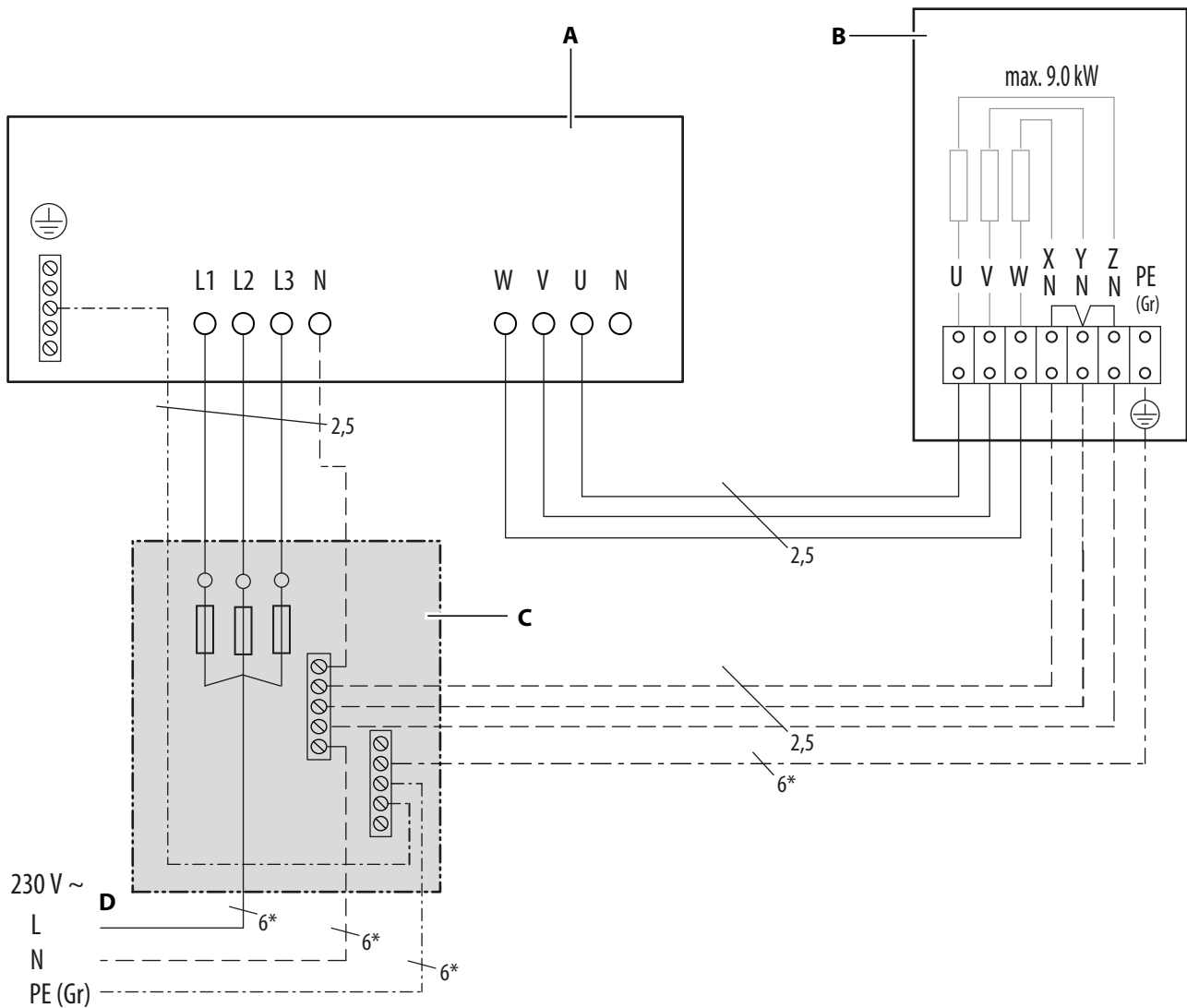

**A** Sauna control unit

**B** Heater

Connection diagram

**C** Distributor for 1-phase connection

**D** Mains connection

\* Cable cross-sections must correspond to the sauna heater output:

- 9 kW – 6 mm<sup>2</sup>

A distributor for the 1-phase connection can be purchased separately:  
Item no. 94.2689



## ⚠ WARNING

### Risk of fire due to improper mounting

The control unit and the sauna heater must be suitable for connection to 230 V 1N ~.

- Use suitable fuses and cable lines.

Rated output per DIN:	9 kW
Fuse protection – control unit	3 x 16 A
Connection mains	3 x 6 mm <sup>2</sup>
Connection control unit – sauna heater	3 x 1.5 mm <sup>2</sup>
Connection N terminal for sauna heater – mains	3 x 2.5 mm <sup>2</sup>
Connection PE terminal for sauna heater – mains	≥ 6 mm <sup>2</sup>

All line cross-section specifications are the minimum cross-sections for copper lines.

## 4.2.3 Internal wiring

### 9 and 10 kW heater output

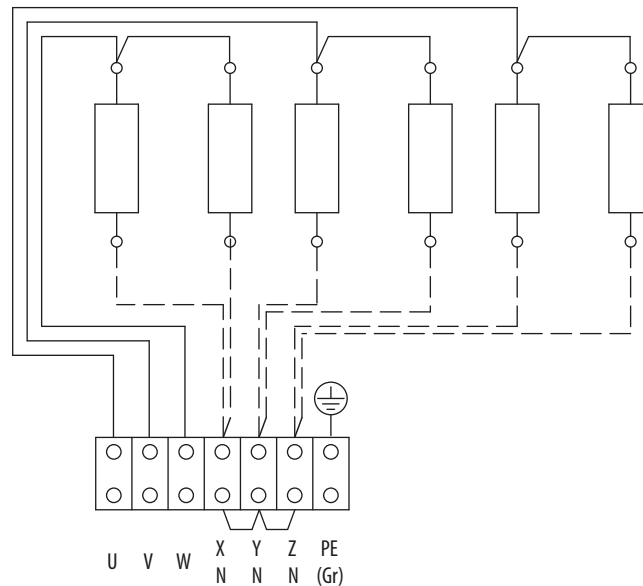

☒ Internal wiring 9 and 10 kW

$$9 \text{ kW} = 6 \times 1500 \text{ W}$$

$$10 \text{ kW} = 6 \times 1666 \text{ W}$$

# Electrical installation

## 12\* and 15\* kW heater output

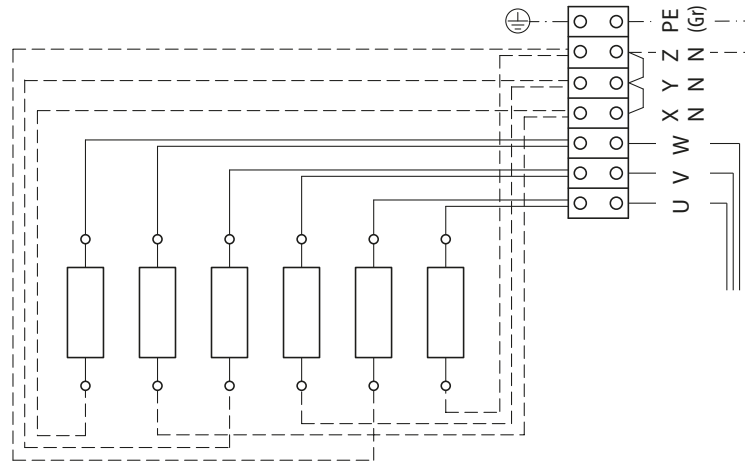

☒ Internal wiring 12 and 15 kW (without LSG)

12 kW = 6x 2000 W

15 kW = 6x 2500 W

\*) Only for connecting to Compact D18/H18 control units.

## 12\*\* and 15\*\* kW heater output (with LSG)

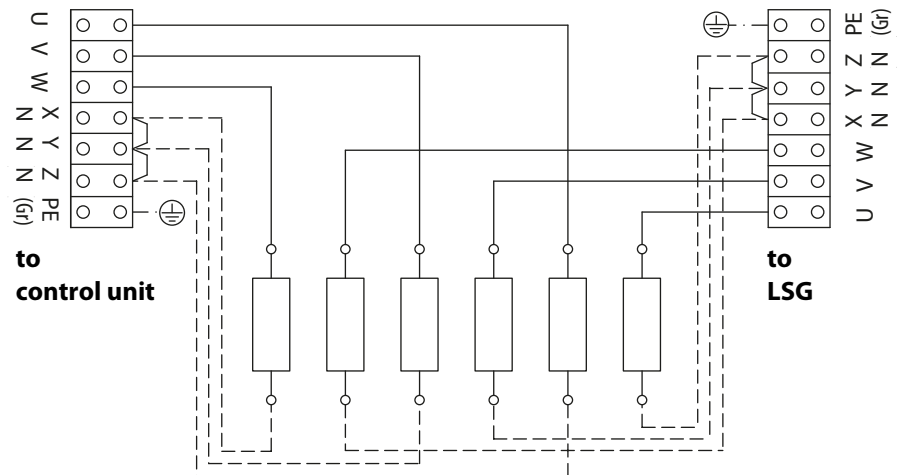

☒ Internal wiring 12 and 15 kW (with LSG)

12 kW = 6x 2000 W

15 kW = 6x 2500 W

\*\*\*) Not for connecting to Compact D18/H18 control units.

## 4.3 Establishing an electrical connection

The connecting cable is pre-mounted on the sauna heater.

The heater is connected to the control unit or to the power extension unit and the control unit via a connecting cable. Observe the regulations of the local power supply company (EVU) and the Association for Electrical, Electronic & Information Technologies (VDE).

Connect the connecting cable to the control unit or to the power extension unit and control unit according to the connection diagrams.

## 4.4 Heating period limitation

All sauna heaters, except for those installed in public saunas, and which must be operated under the supervision of personnel, must be equipped with a timer that complies with IEC and EN standards. For safety reasons, this timer limits the operation time. This timer is typically integrated in all EOS sauna control units.

- The operation time of a public sauna must be limited so that the heating elements are without power for a minimum of 6 consecutive hours within a 24-hour period before an independent restart can take place.
- Units used in private saunas must be limited to an operating time of 6 hours, and an automatic restart is not permitted.

# Commissioning

## 5

### Commissioning

Before the heater can be commissioned, it must be filled with the supplied sauna stones.

Before switching it on, ensure that the air inlets are free of lint. Remove any lint with a moist towel.

The heater is switched on via the control panel for the control unit. It is operated via the control panel.

#### **WARNING**



#### **Fire hazard from overheating**

Objects placed on the heater could catch fire. Herbs or similar substances used for aroma infusion purposes, which are located near the heater, could catch fire.

- ▶ Inspect the cabin prior to each use.
- ▶ Start the sauna only after all air inlets and outlets have been opened.

#### 5.1 Filling with stones

The heater is intended for use with natural sauna stones. Use only stones of the prescribed caliber of approx. 50–100 mm.

#### **WARNING**

#### **Fire hazard from overheating**

Operating the heater without stones could cause fire or damage to the heater. Stones that are too small or are positioned too close together in the heater prevent hot air from being exhausted. This leads to overheating of the heater.

- ▶ Start the heater only if it has been filled with stones.
- ▶ Ensure stones with the correct caliber are used: 50–100 mm.
- ▶ Place the stones loosely in the rock store.

## ► Filling the rock store

- 1 Wash the stones under running water.
- 2 Stack each stone loosely leaving sufficient space between them.
  - ① There must be enough space between the stones so that convection air can circulate sufficiently between them.
  - ② Fill the store with stones only to the upper edge.

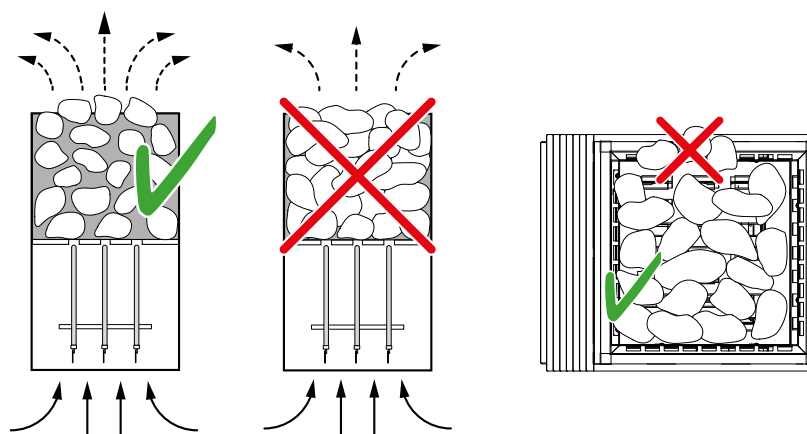

- ① Do not place the stones on the edge. The air must flow freely.

## 5.2 Starting the heater

A slight odour may be produced the first time the cabin is heated because the heater is being heated for the first time. The odour ceases upon continued operation of the heater.

### ► Switching the system on

- 1 Switch on the sauna heater at the control unit.
- 2 Use the control unit to select a suitable program.

## 5.3 Switching the heater on remotely

If you switch on the heater remotely, ensure that no objects are placed on the heater. A suitable safety system, for example EOSafe D/L, can be used to prevent this.

# Commissioning

## 5.4 Water splash

The cabin must be sufficiently heated before making the first water splash. The control panel indicates when the desired temperature has been reached.

### **WARNING**

#### **Risk of fire due to sauna essences**

Incorrectly diluted sauna essences, essential oils or herbs can catch fire.

- ▶ When preparing the water, follow the instructions regarding quantity as specified on the sauna essence containers.
  - ▶ Never add more sauna essence or essential oils to the infusion water than the amount indicated by the manufacturer.
  - ▶ Do not add herbs to the water or on the stones.
  - ▶ Do not use pure sauna essences as a water splash.
  - ▶ Do not use alcohol as a water splash.
  - ▶ Pour the water over the stones only.
- 

Pour water slowly over the stones so it is evenly distributed.

As the hot air rises, steam is distributed evenly in the cabin to create a pleasant infusion experience.

Please note that the sauna stones must be reheated after each water splash to generate an intense burst of steam. After each water splash, wait approx. 10 minutes before starting the next one. This time is needed for the sauna stones to reheat.

Recommendation: During a water splash, no more than approx. 10 cL of water per m<sup>3</sup> cabin volume should be vaporised.

# 6

## Service and maintenance

This sauna heater is made of low-corrosion material. To ensure a long service life, take care of and perform regular maintenance on your sauna heater.

Ensure that openings in the intake area and heat reflectors are never blocked. These can easily become blocked with lint and dust as fresh air is drawn in. This limits the air convection ability of the sauna heater and could lead to impermissible temperatures. Clean and/or descale the units as needed.

If you do not use your sauna for a longer period of time, ensure that at the time of recommissioning no towels, cleaners or other objects are lying on the sauna heater. Contact your sauna retailer or the manufacturer directly if you notice malfunctions or signs of wear and tear.

### 6.1 Cleaning

The heater must be cleaned regularly. The cleaning frequency depends on how often it is used.

#### **⚠ CAUTION**

##### **Risk of injury from sharp edges**

- ▶ Use suitable personal protective equipment, e.g. gloves, when cleaning parts with sharp edges.

##### **▶ Cleaning the heater**

- 1 Switch off the heater from the control unit.
  - ① Wait until the heater is completely cool.
- 2 Clean the outside of the heater.
  - ① Use only household cleaning agents.
- 3 Remove lint and dust from openings and heat reflectors.
  - ① Openings can easily become blocked with lint and dust as fresh air is drawn in. This limits the air convection ability of the heater and could lead to impermissible temperatures.

## Service and maintenance

### 6.2 Sauna stones

Sauna stones are a product of nature. Stones must be reshuffled depending on the frequency of use.

The process of heating and cooling can make the stones brittle. Particular damage to the stones can be caused by aggressive sauna essences, causing them to disintegrate over time. Small particles can break free from the stones making the gaps between the stones smaller. This means that hot air can no longer rise between the stones.

Check the sauna stones regularly and reshuffle them. Replace damaged stones.

Please observe the following frequencies of time.

Commercial use	Private use
Every 2–3 months	Once per year

Use only natural sauna stones when you replace the old stones with new ones. Due to their roughness, they produce a better water splash effect than ceramic sauna stones.

#### ► Reshuffling the sauna stones

- 1 Switch off the heater from the control unit.
- 2 CAUTION! Caution: stones may be hot. Allow the heater to cool sufficiently before you start to replace the stones.  
Remove each stone individually.
- 3 Check each stone for damage.
  - ⓘ Sort out any stones with severe damage.
  - ⓘ Replace stones that have been sorted out: new stone caliber 50–100 mm
- 4 Rinse all stones with cold water.
- 5 Place the stones loosely so that there is enough space between them for air to circulate sufficiently.
  - ⓘ ► Filling the rock store, 📄 EN-37



## 6.3 Replacing the tubular heating elements

You can replace individual tubular heating elements or the entire heating coil.

If the heater is too close to the wall, it may be necessary to move it so that you can access the rear side. To move the heater more easily, remove stones.

Necessary steps:

- ▶ Removing the heating coil, [EN-41](#)
- ▶ Replacing the tubular heating elements, [EN-44](#)
- ▶ Inserting the heating coil, [EN-45](#)

Hardware and tools:

- Tubular heating element or heating coil
- Screwdriver
- Ring or socket spanner

### **⚠ CAUTION**

#### **Risk of injury from sharp edges**

- ▶ Use suitable personal protective equipment (e.g. gloves) when cleaning parts with sharp edges.

#### **▶ Removing the heating coil**

- 1** **WARNING!** Electric shock may occur if the heating coil is serviced while the heater is connected to the power supply.  
Ensure that the heater has been disconnected from all power supply lines.
  - a)** Switch off the heater.
  - b)** Switch off the fuses to disconnect the heater from the mains supply.
- 2** **CAUTION!** Allow the heater to cool sufficiently before starting work.  
Remove the stones.
- 3** **NOTICE** Cover the floor in front of the heater to prevent damage to the floor.  
Move the heater only by the base plate. Do not lift the heater.  
If necessary, pull the heater away from the wall if the rear of the heater cannot be reached.

## Service and maintenance

- 4 Loosen the screws in both back panels and remove them.

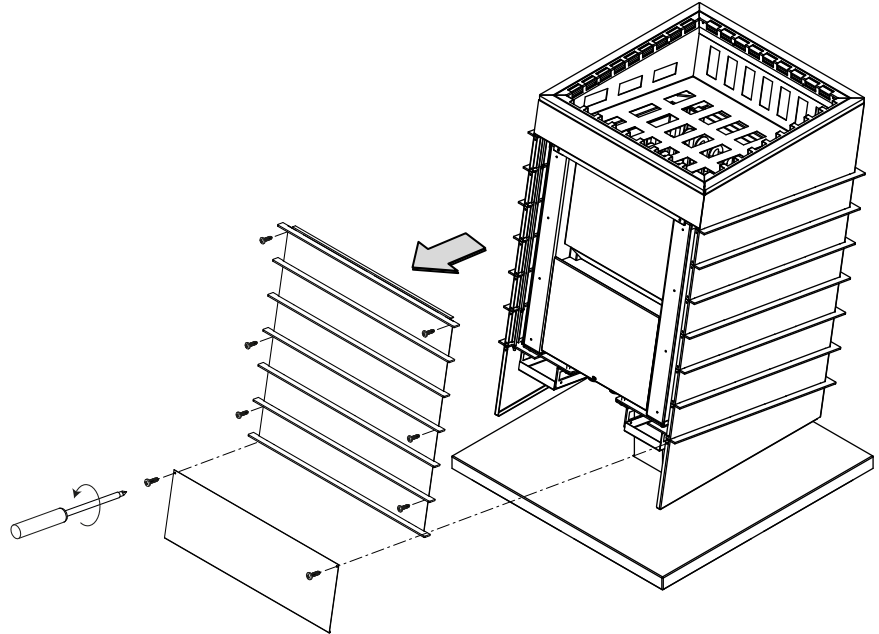

- 5 Loosen the screw on the cover of the terminal box and remove the cover.

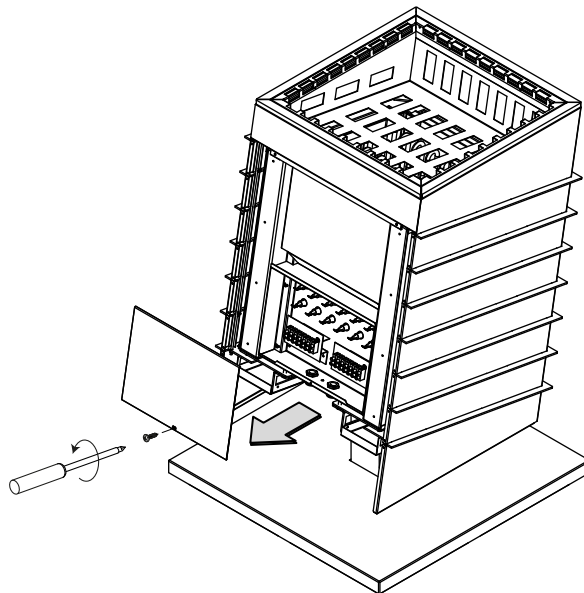

- 6 Loosen the connecting cable from the connection terminals.

- 7 Feed the connecting cables through the cable screw connections out from the terminal box.

- 8 Unscrew the 4 screws in the heating coil.
- 9 Pull out the terminal box with the heating coil. To do this, first press the heating coil down slightly and then pull it out forwards.

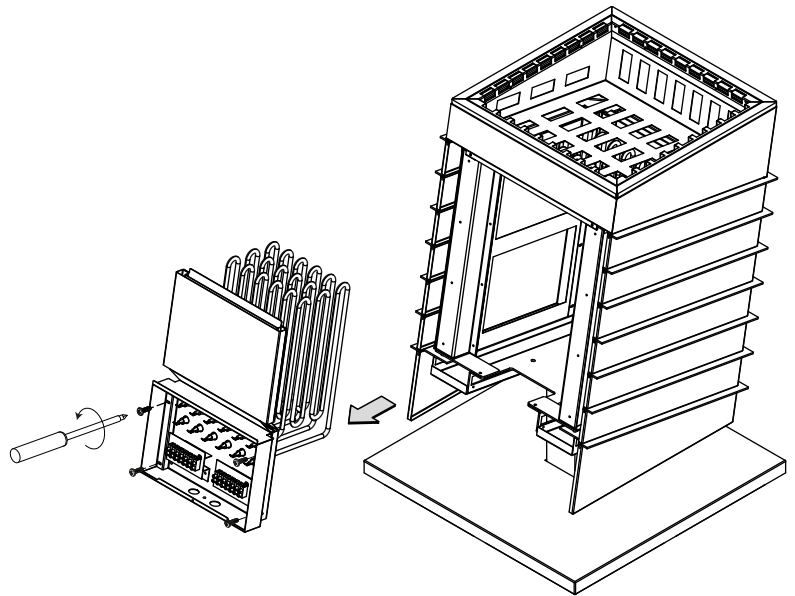

- 10 Check drip trays below the heating coil for dirt and debris and clean if necessary.

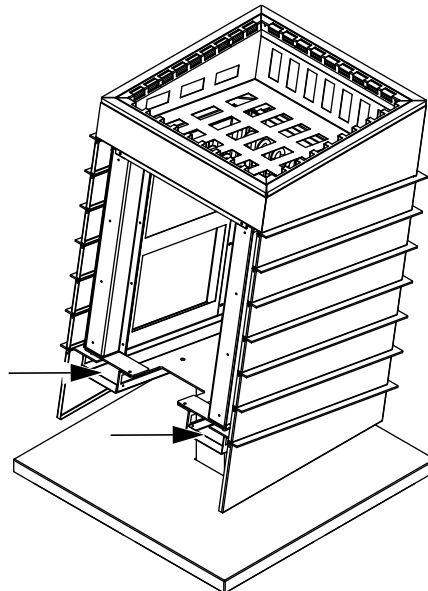

## Service and maintenance

### ► Replacing the tubular heating elements

- 1 Remove the heating coil.  
 ⓘ ► Removing the heating coil, [EN-41](#)
- 2 Identify the defective heating element by taking measurements.
- 3 Remove both flat plugs from the defective heating element.

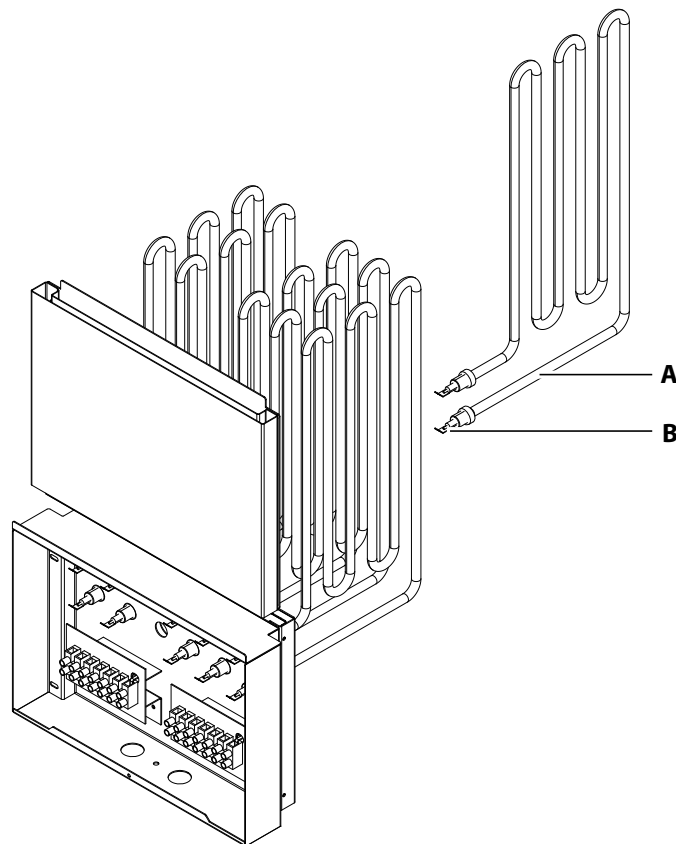

**A** Heating element

**B** Flat pin

- 4 Loosen the 2 fixing nuts and serrated washers on the defective heating element.
- 5 Press the heating element slightly backwards and remove it upwards.
- 6 Insert the new heating element.
- 7 Fix the heating element with the serrated washers and the fixing nuts.
- 8 Plug in the flat plug.  
 ⓘ Check the wiring on all heating elements before reclosing the terminal box and setting up the heater.

## ► Inserting the heating coil

- 1 Insert the heating coil into the heater.
  - ① Ensure that the tab on the air deflection hood is seated in the recess provided.

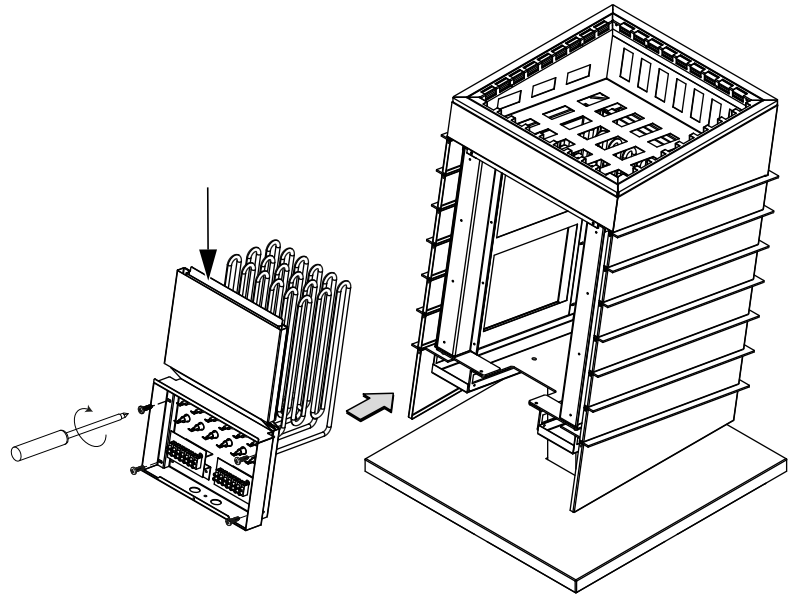

- 2 Screw in the 4 screws in the heating coil and tighten.
- 3 Feed the connecting cables through the cable screw connections in the terminal box.
- 4 Connect the connecting cables.
  - ① 4.2 Inner wiring diagrams, DE-28
- 5 Put on the covers of the terminal box and the rear panel of the heater.
- 6 Move the heater back into its original position.
- 7 Place the stones in the rock store.
- 8 Switch on the fuses of the heater.

## Service and maintenance

### 6.4 Troubleshooting

Error	Reason	Solution
It takes the heater a long time to heat up the cabin.	One or more than one heating element is defective.	Have a technician replace the tubular heating element.
	There is not enough space between the stones.	Reshuffle the stones. See ► Reshuffling the sauna stones, EN-40
	There is insufficient ventilation.	Install the air inlets. If these are insufficient, add a fan to the openings. See 3.1.2 Air inlets and outlets, EN-17
	The electrical connection is defective.	Check the installation fuses. Have the control unit's outputs checked by a technician.
	The position of the temperature sensor is not optimal.	Check the position of the temperature sensor and adjust as needed. See 3.1.3 Temperature sensor, EN-19
The heater is very hot but cannot distribute the heat throughout the cabin.	There is not enough space between the stones.	Reshuffle the stones. See ► Reshuffling the sauna stones, EN-40
The safety temperature limiter was triggered and the heater no longer heats.	The STB was triggered by heat accumulation.	Check the inlets, outlets, and the fan and ensure that the heater has access to a sufficient amount of air. Replace the safety temperature limiter.
	The position of the temperature sensor in the cabin is not optimal.	Check the position of the temperature sensor and adjust as needed. See 3.1.3 Temperature sensor, EN-19.

# 7

## General terms and conditions of service

(T&C, Dated 08-2018)

### I. Scope

Unless otherwise agreed in writing for specific instances, these terms and conditions of service shall apply to service operations, including reviewing and remedying complaints. All our existing or future legal relationships shall be governed solely by the following terms and conditions of service. We do not recognise any of the customer's conflicting terms and conditions unless we have given our express written consent to their applicability.

We hereby expressly object to any of the customer's terms and conditions included in the customer's General Terms and Conditions of Business or order confirmation. Unconditional acceptance of order acknowledgments or deliveries shall not be construed as any form of acknowledgment of such terms and conditions. Ancillary agreements or amendments must be confirmed in writing.

### II. Costs

The customer shall bear the following costs in connection with services rendered:

- Mounting/dismantling and electrical (de-)installation
- Transportation, postage and packaging
- Function testing and troubleshooting, including inspection and repair costs

There shall be no third-party billing.

### III. Performance and cooperation obligations

The customer shall provide assistance free of charge to the manufacturer in rendering services.

In the case of a warranty claim, the manufacturer shall provide spare parts necessary for servicing free of charge.

# General terms and conditions of service

## IV. Service visit by the manufacturer

Services rendered on site by an employee of the manufacturer must be agreed in advance.

If the main reason for the service visit is not the fault of the manufacturer, any costs incurred shall be charged to the customer after the service visit and must be paid by the customer in full within the agreed payment term.

## V. Liability

The manufacturer shall assume liability in accordance with the currently applicable statutory regulations. All our products are packaged in such a way that the individually packed goods (pallets) can be shipped.

We wish to point out that our packaging is not suitable for individual shipments via parcel post. The manufacturer shall accept no liability for damages incurred as a result of improper packaging in an individual shipment.

## VI. Manufacturer's warranty

The manufacturer's warranty shall apply only if installation, operation and maintenance have been carried out in full accordance with the manufacturer's specifications in the installation and operating instructions.

- The warranty period shall commence from the date on which proof of purchase is provided and shall be limited, in all cases, to 24 months.
- Warranty services shall be performed only if proof of purchase of the equipment can be presented.
- Any and all warranty claims shall become void if modifications are made to the equipment without the manufacturer's express consent.
- Any warranty claim shall likewise become void in the case of defects that arise due to repairs or interventions made by unauthorised persons or due to improper use.
- In the case of warranty claims, the serial and article numbers must be provided, together with the unit designation and a meaningful description of the error.
- This warranty shall cover defective equipment parts, with the exception of normal wear parts. Wear parts shall include, for example, light sources, glass elements, tubular heating elements and sauna heater stones.
- Only original spare parts may be used within the warranty period.
- Service visits made by third parties shall require a written order issued by our service department.



- The equipment in question shall be sent to our service department by the customer at the customer's own expense.
- Electrical assembly and installation work, including service visits and parts replacements, shall be carried out at the customer's expense; costs shall not be borne by the manufacturer.

Complaints in respect of our products shall be reported to the responsible distributor and shall be handled exclusively by said distributor.

The manufacturer's General Terms and Conditions of Business, in the version available at [www.eos-sauna.com/agb](http://www.eos-sauna.com/agb), shall apply in addition to the foregoing terms and conditions of service.

# Disposal

## 8

### Disposal

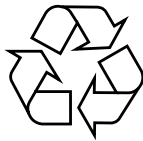

Electrical devices that are no longer needed must be recycled at a recycling station as per EU guideline 2012/19/EU or as per the Electrical and Electronic Equipment Act (ElektroG). Observe local provisions, laws, regulations, standards and directives when disposing of the unit.



Do not dispose of the unit with household waste.



#### Packaging

The packaging of the unit can be completely separated for disposal and recycled. The following materials are used in the packaging:

- Used paper/cardboard
- Plastic foil

#### Electronic waste

Electronic waste must be disposed of at the designated local collection point for electronic waste.

#### Additional disposal instructions for commercial users (DE only)

You can find further disposal instructions under [www.eos-sauna.com/recycling](http://www.eos-sauna.com/recycling)



**made in Germany**

**CE UK  
CA IPx4**

Stand 09/2024  
Druck-Nr. 2902 5209  
All rights reserved.